

Offificio®

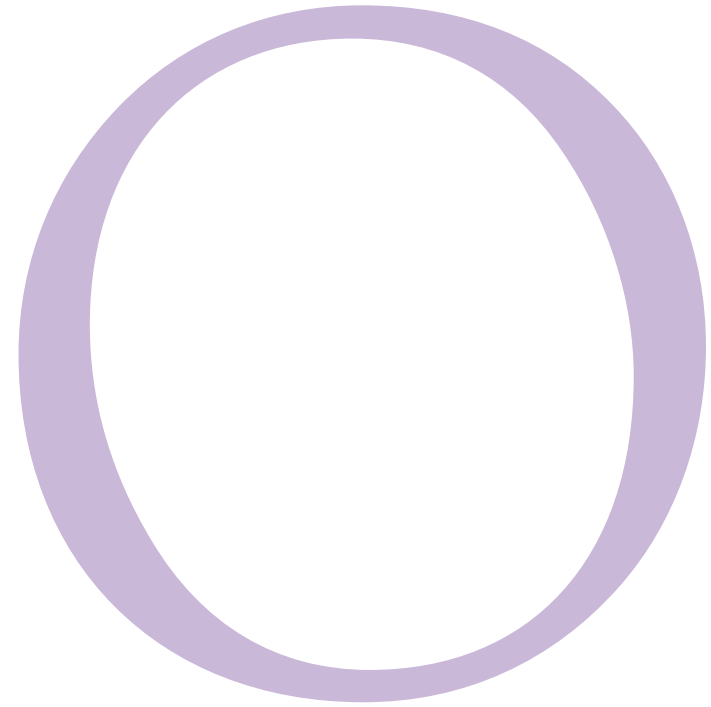

VELLUTI E TESSUTI D'ARREDAMENTO
FABRICS AND VELVETS FOR INTERIORS

ARREDAMENTO SOFFICE
SU MISURA
SOFT FURNISHING
BESPOKE

Si fa notare che trattandosi di fotografie non sempre i colori a catalogo risultano essere assolutamente fedeli all'originale.
Please notice that, in this catalogue, we have tried to have reproductions as true as possible to the original colour of fabrics and velvets.



L1154

1^o Opificio

Verso





VE1112

Opificio

Verso





L1157

rOpificio

Verso



L1580



Metropolitán





L1595





L1590

L1520

Classic







L1530



Diva





L1541



Twist

Twist



L1548





L1560

Opificio

Icona





L1568

l'Opificio

Icona





EPO1805



Le Collezioni



KO2701

MEL409

rOpificio

Le Collezioni





COT2150

rOpificio

Le Collezioni



OP1600



Optical

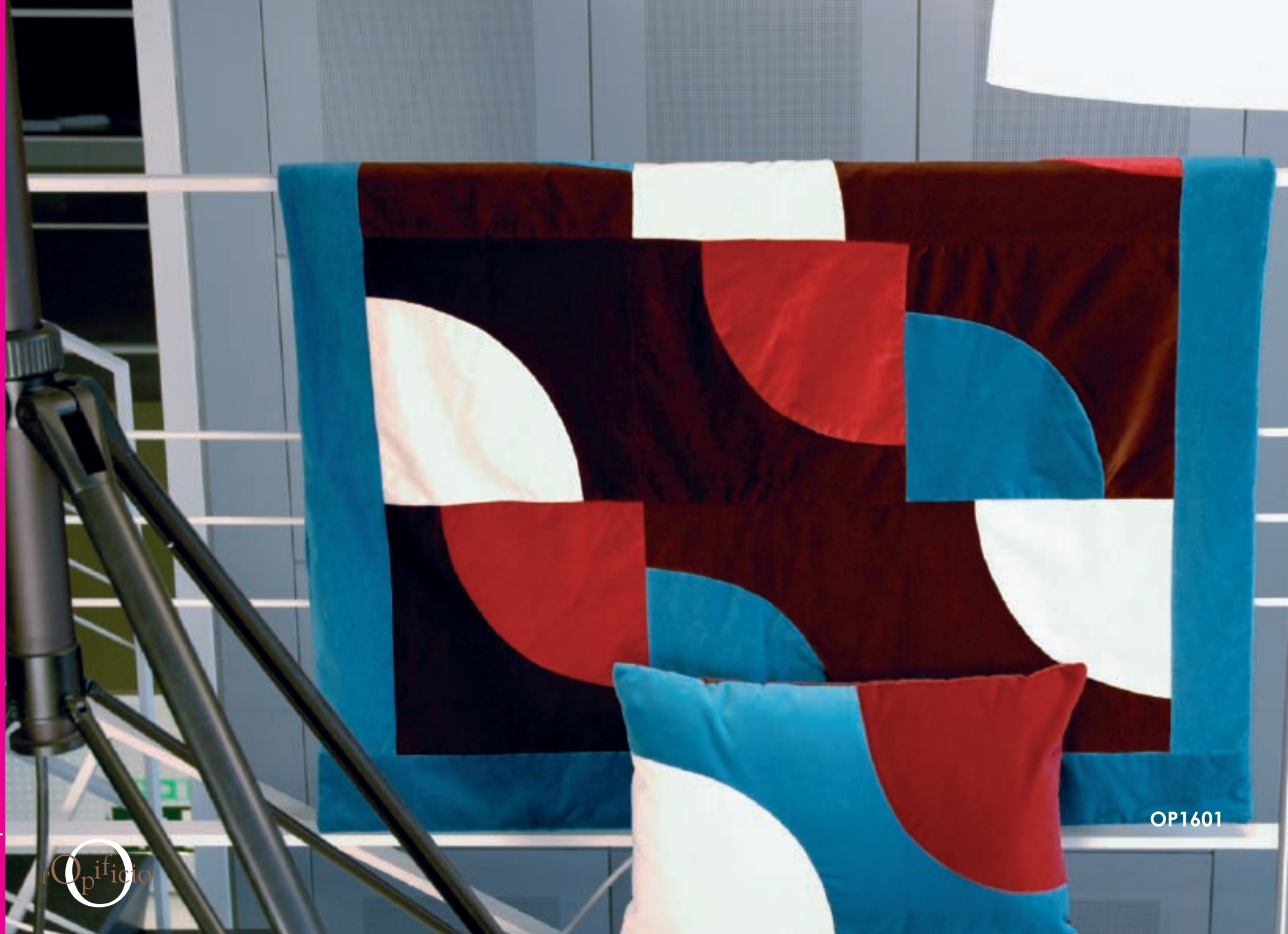



OP1604

Opificio

Optical



RE1622



Rebous



RE1623



SM2501



Smart





HA1901



Kaleido



KA106





SH2600

Opificio

Shiro



L1570



Eclettica



Cuscini

CUF3333E



CUA4343E/ FASCIA



CUD6565E/ BOTTONE



CUA4343E



CUA5050E



CUT120120E



CUA4343E/ BOTTONE



CUA5050E/ BOTTONE



CUQ2042E



CUE6530E/ ALLUNGATO



CUC3570E



CU2042E/ FRIVOLO



CUL2055E



CUV3570E



CU2540E/ELLE



CUI2848E



CUG3580E/ BAGUETTE



CUR2045E



CUS3570E



CUE2540E



CUB2850E



CUU4545E/ GIAP PATCH



CUH6030E/PETIT BONBON



CUU4545E/ GIAP



CUH5540E BONBON



CUU6060E/ GIAP PATCH



CUO9040E/NOISETTE



CUU6060E/ GIAP



CUM2280E/RULLO





Materassi



MODEL - MATERASSO 55X100



MODEL - MATERASSO 55X55





Poufs

Poufs

MODEL - POUF 43X43X43



MODEL - POUF 60X60X40



MODEL - POUF 70X40X35



MODEL - POUF ø40X43



L'Offificio[®]

Schede tecniche
Specifications

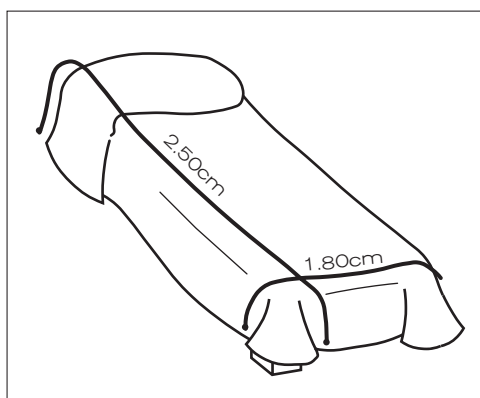
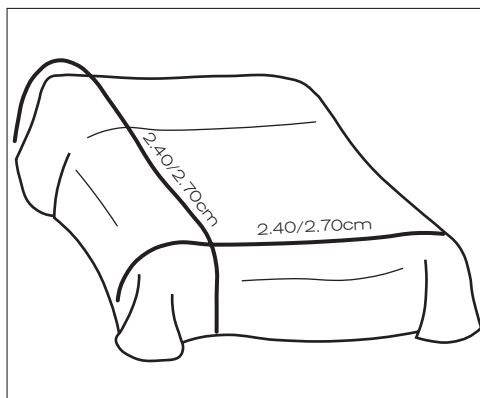
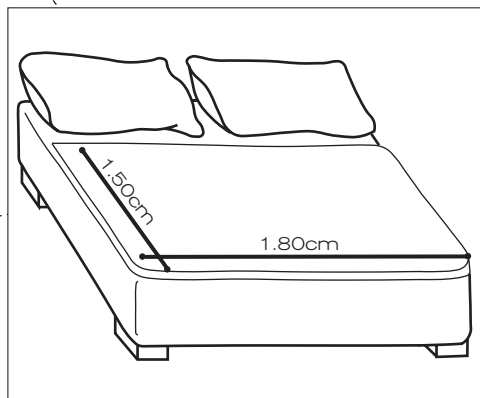

IL SERVIZIO "SU MISURA"

Un'eleganza sottile e raffinata quella proposta da l'Opificio che trova il suo culmine nei pezzi unici creati su misura dall'atelier. Il capo viene personalizzato e calibrato sulle esigenze del cliente, dalle misure agli abbinamenti colore, dai tessuti fino alle imbottiture.

VESTIBILITÀ

Le dimensioni standard proposte in catalogo sono pensate per materassi di dimensioni cm 80x190/200 per il letto singolo e cm 160x190/200 per il letto matrimoniale con altezza da filo superiore materasso a terra di cm 60 circa.

BESPOKE SERVICE

A subtle and refined elegance is what l'Opificio proposes which finds its maximum expression in unique bespoke home accessories from our atelier.

Each article is personalized and tailored according to the wishes of the customer from the dimensions to the colour combinations, from textiles to filling.

DRESSING THE BED

The standard dimensions proposed in our catalogue are based on a mattress of 80x190/200 for the single bed and 160x190/200 for the double bed with an height from top mattress to floor of about 60 cm.

Su Misura Bespoke

SU MISURA BESPOKE

l'Opificio®

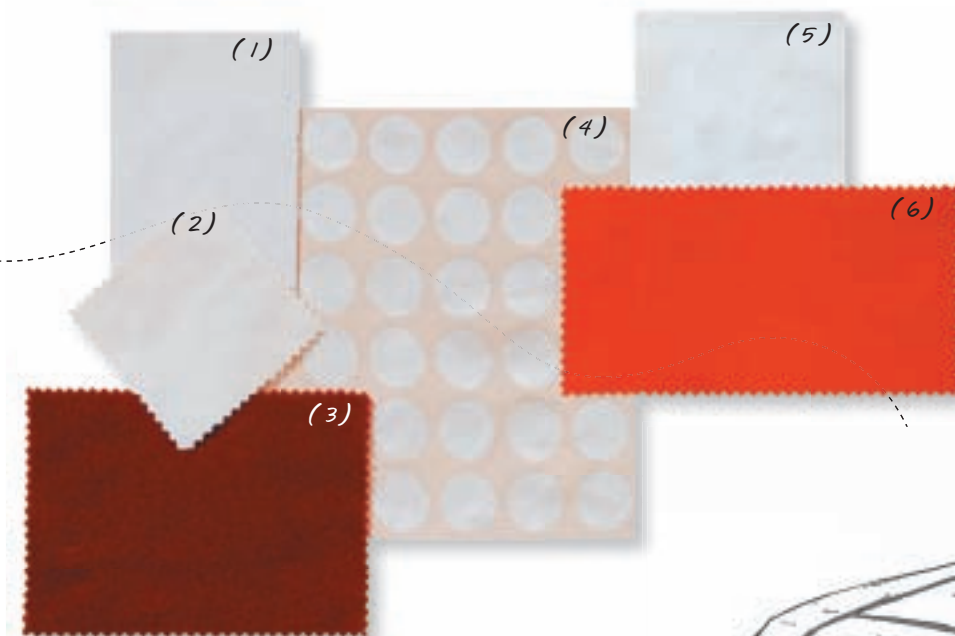

model "Le Collezioni"
240x240cm

- (1) Coll. Velluto di Cotone col. 0010
- (2) Coll. Satin col. 1010
- (3) Coll. Velluto di Cotone col. 0513
- (4) Coll. Kosmo Pois art. KO 0136 col. 1010
- (5) Coll. Alari col. 1000
- (6) Coll. Alari col. 7027

CUSCINI

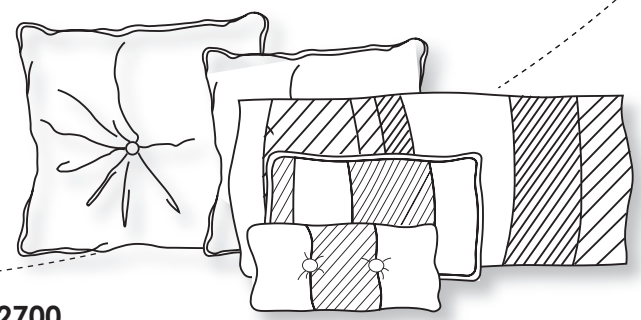

KO2700



model CUG 35x80cm



model CUI 28x48cm

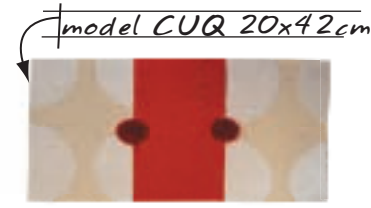

model CUQ 20x42cm

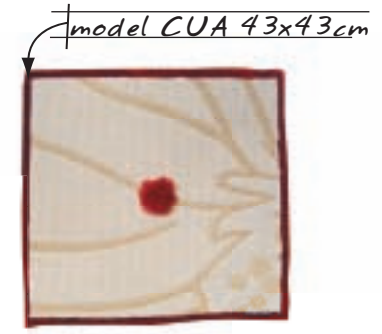

model CUA 43x43cm

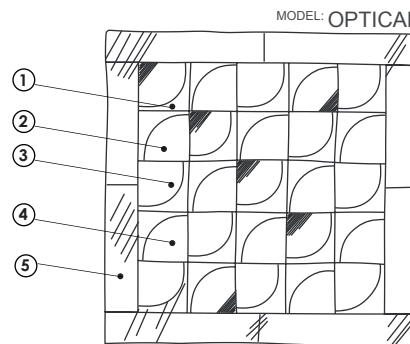
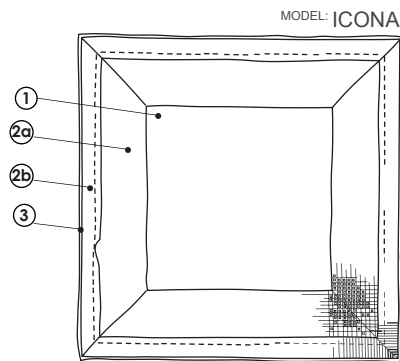
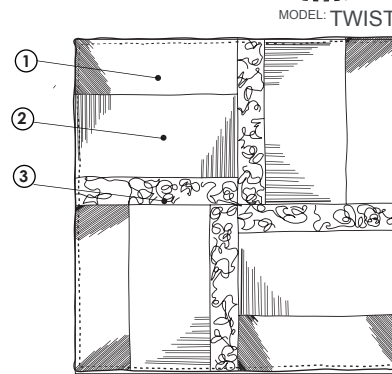
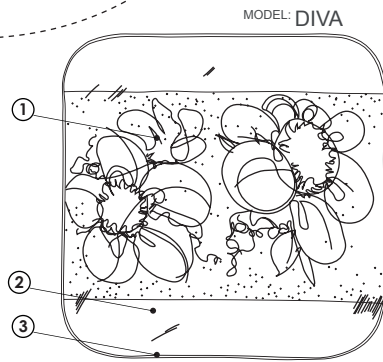
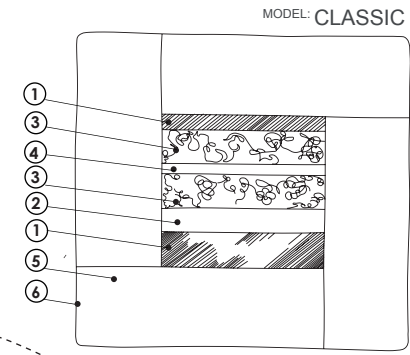
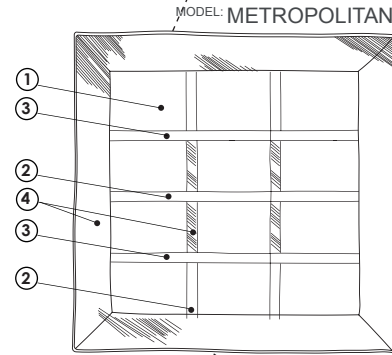
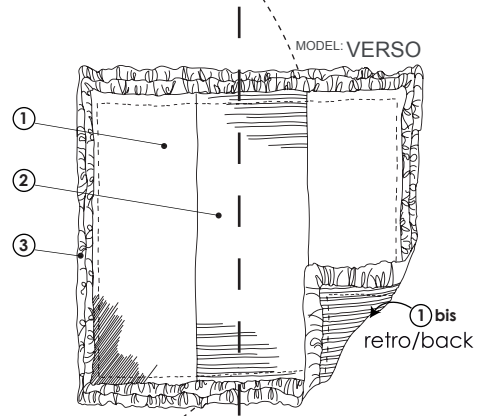

MODELLI
Trapuntini
MODEL QUILTS

I numeri indicano la disposizione dei tessuti / Numbers indicate the fabrics positions

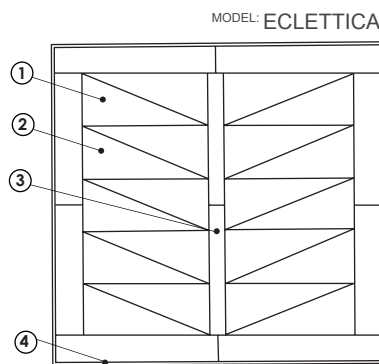
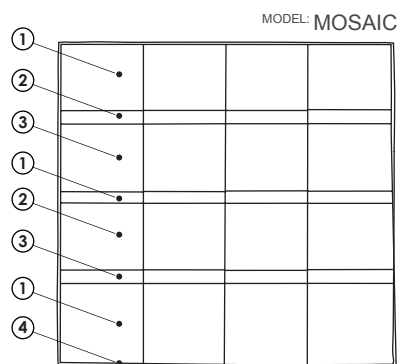
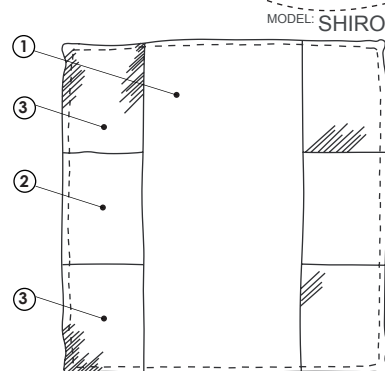
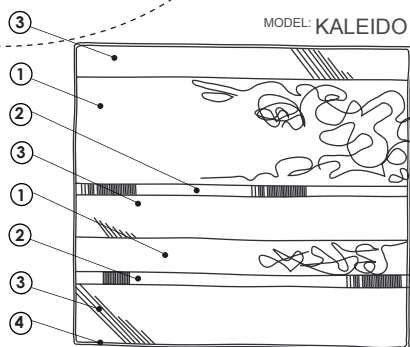
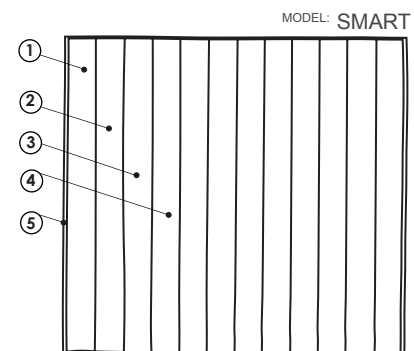
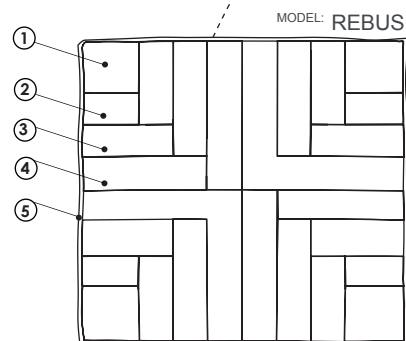
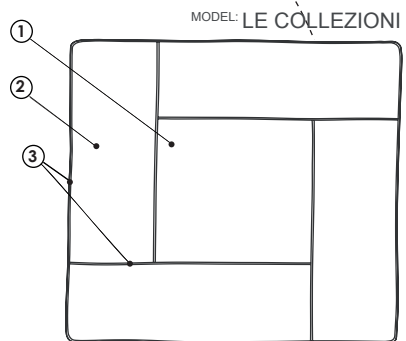

MODELLI
Trapuntini
 MODEL QUILTS

I numeri indicano la disposizione dei tessuti / Numbers indicate the fabrics positions

MISURE/DIMENSIONS

Matrimoniale - Double Bed

cm 240x240 / cm 270x270

Scaldotto - Plaid

cm 140x240

Disponibile con imbottitura fissa.
Available with fixed filling.

SU MISURA

Ogni modello proposto può essere personalizzato nelle dimensioni e nell'imbottitura e confezionato utilizzando i tessuti e i velluti di tutte le collezioni l'Opificio

BESPOKE

Each model can be personalized in the dimensions and in the filling and it can be manufactured making use of the wide offer of the l'Opificio Fabrics and Velvets Collections.

UTILIZZARE IL SEGUENTE FORM:
PLEASE USE THE FOLLOWING FORM:

QUANTITÀ/QUANTITY: n° _____
MISURE/DIMENSIONS: cm _____
① TOP 2-3 tessuti/fabrics: _____ _____ _____
② PROFILO/EDGE _____ _____
③ RETRO/BACK _____ _____

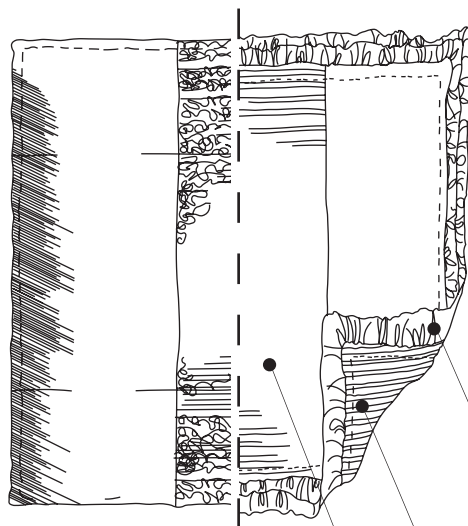

① TOP 2-3 tessuti/fabrics

Indica tutti i tessuti e velluti della parte centrale del trapuntino.
Indicates all the fabrics and velvet of the central part of the quilt.

② RIFINITURA/FINISHING

Filza
Running stitch

Disponibile nella versione con o senza ruches lungo il profilo.
Available with or without frill around the edge.

③ RETRO/BACK

Disponibile anche nella versione double-face.
Also available in the double face version.

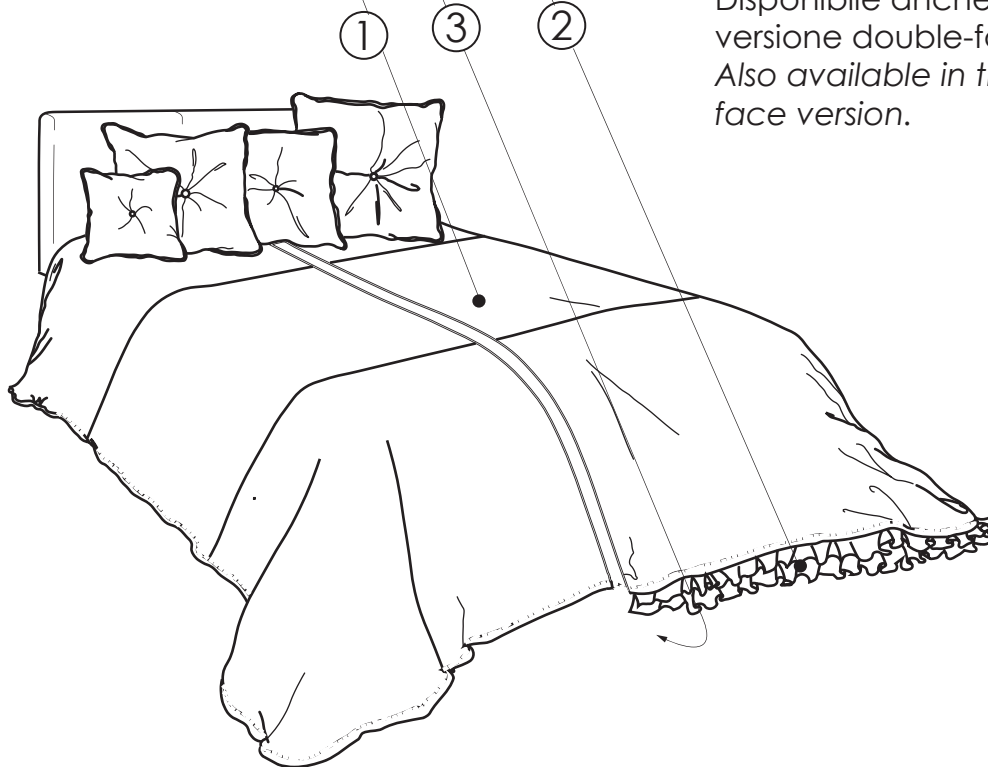

Verso

MISURE/DIMENSIONS

Matrimoniale - Double Bed

cm 240x240 / cm 270x270

Scaldotto - Plaid

cm 150x180

Disponibile con imbottitura fissa o estraibile.

Available with extractable or fixed filling.

SU MISURA

Ogni modello proposto può essere personalizzato nelle dimensioni e nell'imbottitura e confezionato utilizzando i tessuti e i velluti di tutte le collezioni l'Opificio

BESPOKE

Each model can be personalized in the dimensions and in the filling and it can be manufactured making use of the wide offer of the l'Opificio Fabrics and Velvets Collections.

UTILIZZARE IL SEGUENTE FORM:

PLEASE USE THE FOLLOWING FORM:

QUANTITÀ/QUANTITY: n° _____

MISURE/DIMENSIONS: cm _____

① TOP 3 tessuti/fabrics:

② BORDO/BORDER

③ PROFILO/EDGE

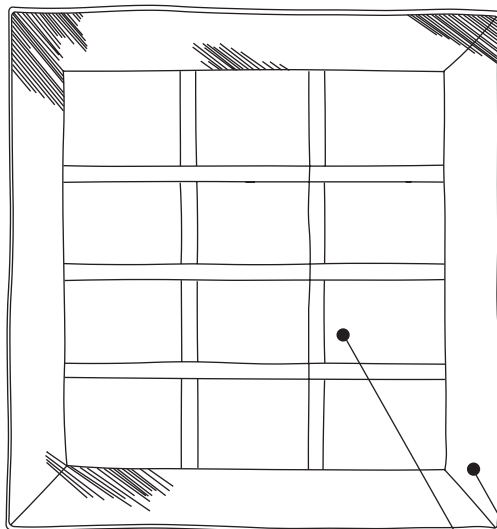

① TOP 3 tessuti/fabrics .

Indica tutti i tessuti e velluti della parte centrale del trapuntino. Indicates all the fabrics and velvet of the central part of the quilt.

② BORDO/BORDER

③ PROFILO/EDGE



Metropolitan

MISURE/DIMENSIONS

Matrimoniale - Double Bed

cm 240x240 / cm 270x270

Scaldotto - Plaid

cm 150x180

Disponibile con imbottitura fissa o estraibile.

Available with extractable or fixed filling.

SU MISURA

Ogni modello proposto può essere personalizzato nelle dimensioni e nell'imbottitura e confezionato utilizzando i tessuti e i velluti di tutte le collezioni l'Opificio

BESPOKE

Each model can be personalized in the dimensions and in the filling and it can be manufactured making use of the wide offer of the l'Opificio Fabrics and Velvets Collections.

UTILIZZARE IL SEGUENTE FORM:

PLEASE USE THE FOLLOWING FORM:

QUANTITÀ/QUANTITY: n° _____

MISURE/DIMENSIONS: cm _____

① TOP 4 tessuti/fabrics:

② BORDO/BORDER

③ PROFILO/EDGE

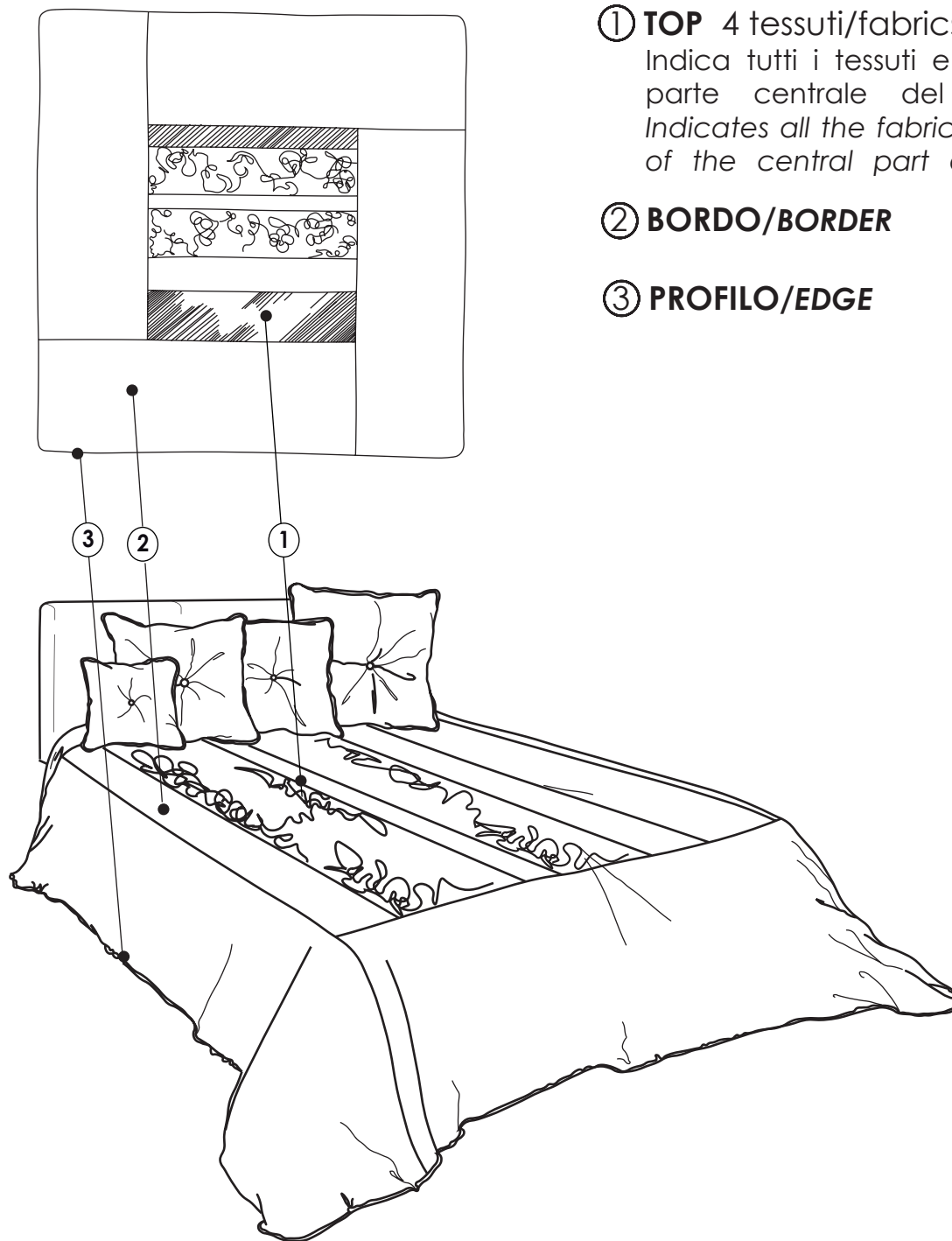

① TOP 4 tessuti/fabrics

Indica tutti i tessuti e velluti della parte centrale del trapuntino. Indicates all the fabrics and velvet of the central part of the quilt.

② BORDO/BORDER

③ PROFILO/EDGE

Classic

MISURE/DIMENSIONS

Matrimoniale - Double Bed

cm 240x240 / cm 270x270

Scaldotto - Plaid

cm 150x180

Disponibile con imbottitura fissa o estraibile.

Available with extractable or fixed filling.

SU MISURA

Ogni modello proposto può essere personalizzato nelle dimensioni e nell'imbottitura e confezionato utilizzando i tessuti e i velluti di tutte le collezioni l'Opificio

BESPOKE

Each model can be personalized in the dimensions and in the filling and it can be manufactured making use of the wide offer of the l'Opificio Fabrics and Velvets Collections.

UTILIZZARE IL SEGUENTE FORM:
PLEASE USE THE FOLLOWING FORM:

QUANTITÀ/QUANTITY: n° _____
MISURE/DIMENSIONS: cm _____
① TOP 1 tessuto/fabric: _____
② BORDO/BORDER _____
③ PROFILO/EDGE _____

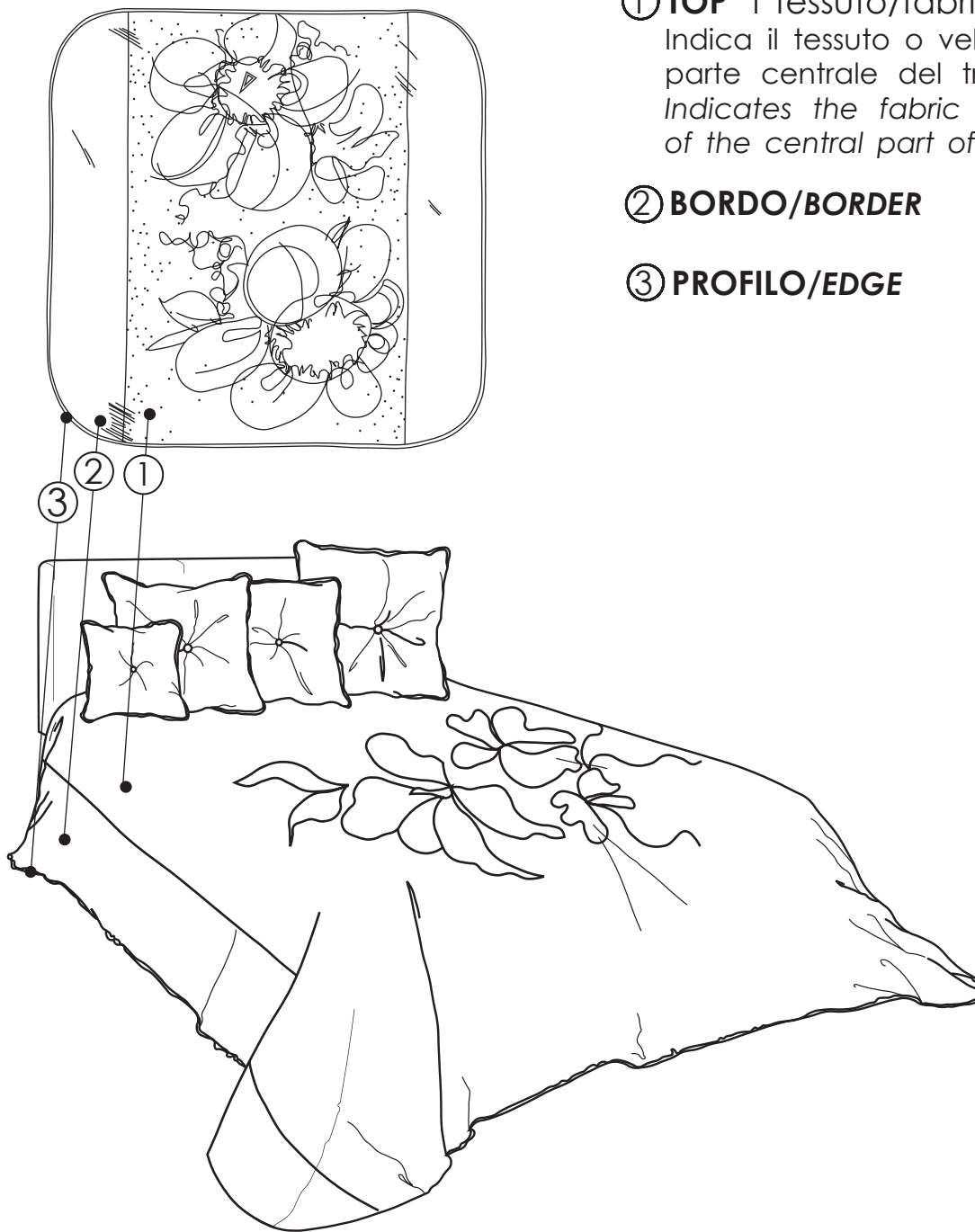

① **TOP 1 tessuto/fabric**
Indica il tessuto o velluto della parte centrale del trapuntino.
Indicates the fabric or velvet of the central part of the quilt.

② **BORDO/BORDER**

③ **PROFILO/EDGE**

Divò

MISURE/DIMENSIONS

Matrimoniale - Double Bed

cm 240x240 / cm 270x270

Scaldotto - Plaid

cm 160x160

Disponibile con imbottitura fissa.
Available with fixed filling.

SU MISURA

Ogni modello proposto può essere personalizzato nelle dimensioni e nell'imbottitura e confezionato utilizzando i tessuti e i velluti di tutte le collezioni l'Opificio

BESPOKE

Each model can be personalized in the dimensions and in the filling and it can be manufactured making use of the wide offer of the l'Opificio Fabrics and Velvets Collections.

UTILIZZARE IL SEGUENTE FORM:
PLEASE USE THE FOLLOWING FORM:

QUANTITÀ/QUANTITY: n° _____
MISURE/DIMENSIONS: cm _____
① TOP 3 tessuti/fabrics:

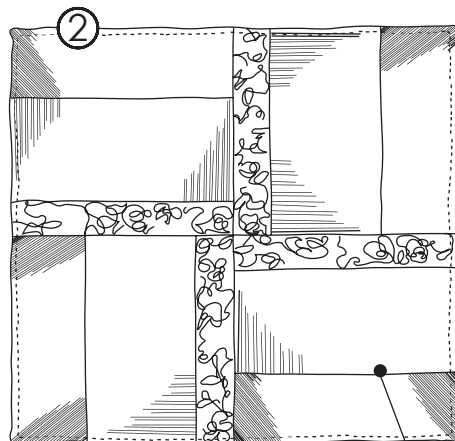

① TOP 3 tessuti/fabrics

Indica tutti i tessuti e velluti della parte centrale del trapuntino.
Indicates all the fabrics and velvet of the central part of the quilt.

② RIFINITURA/FINISHING

Filza.

Running stitch.

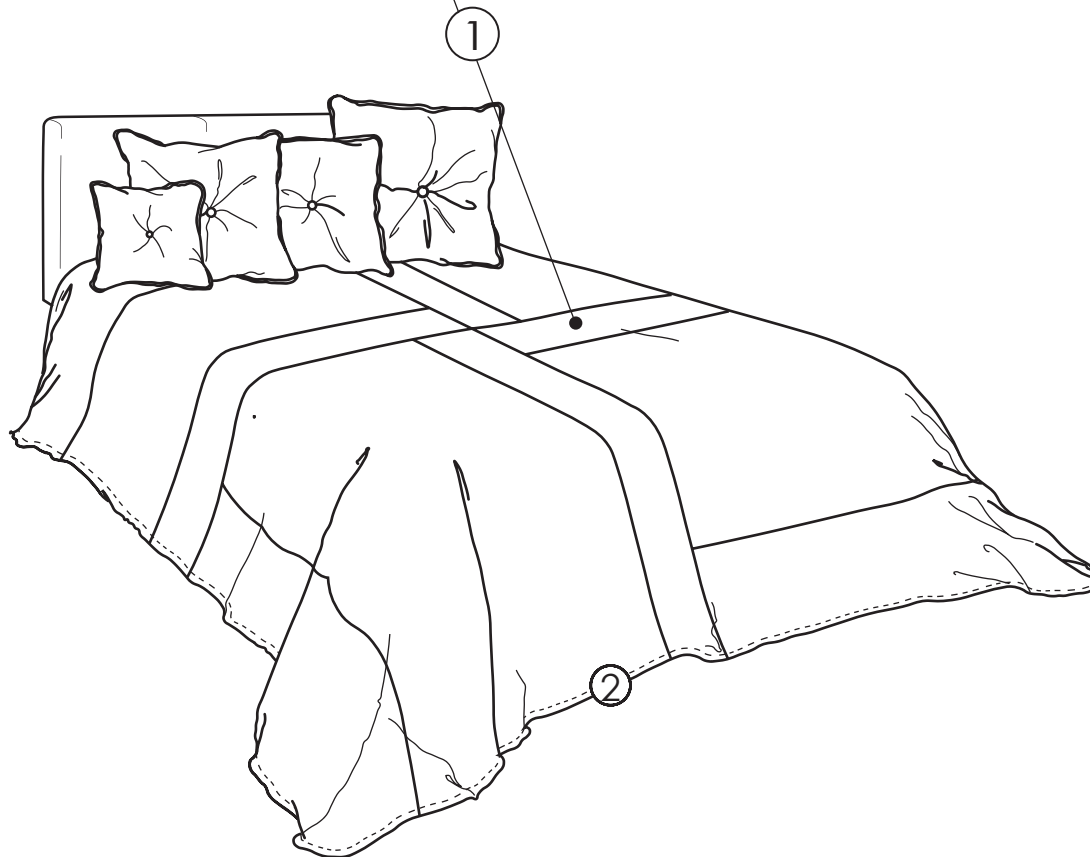

Twist

MISURE/DIMENSIONS

Matrimoniale - Double Bed

cm 240x240 / cm 270x270

Scaldotto - Plaid

cm 150x180

Disponibile con imbottitura fissa.

Available with fixed filling.

SU MISURA

Ogni modello proposto può essere personalizzato nelle dimensioni e nell'imbottitura e confezionato utilizzando i tessuti e i velluti di tutte le collezioni l'Opificio

BESPOKE

Each model can be personalized in the dimensions and in the filling and it can be manufactured making use of the wide offer of the l'Opificio Fabrics and Velvets Collections.

**UTILIZZARE IL SEGUENTE FORM:
PLEASE USE THE FOLLOWING FORM:**

QUANTITÀ/QUANTITY: n° _____

MISURE/DIMENSIONS: cm _____

① TOP 2 tessuti/fabrics:

② BORDO/BORDER

③ PROFILO/EDGE

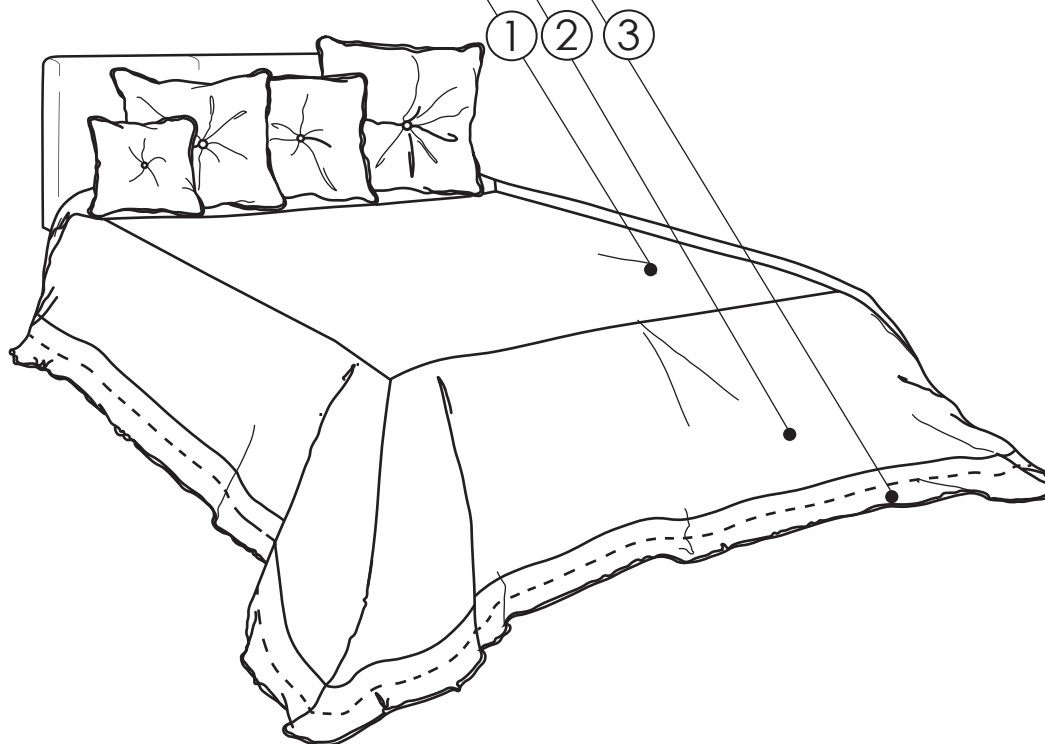
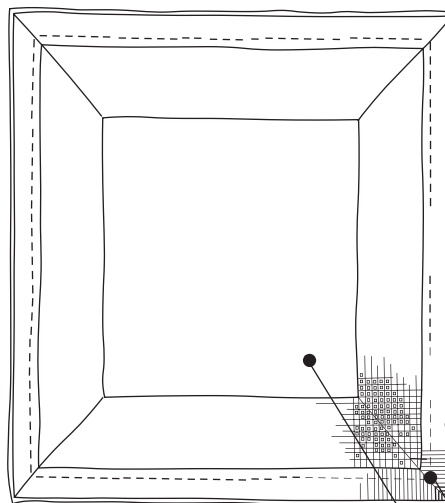

① TOP 2 tessuti/fabrics

Indica tutti i tessuti e velluti della parte centrale del trapuntino.
Indicates all the fabrics and velvet of the central part of the quilt.

② BORDO/BORDER

③ RIFINITURA/FINISHING

Filza
Running stitch

③ PROFILO/EDGE

Icona

MISURE/DIMENSIONS

Matrimoniale - Double Bed

cm 240x240 / cm 270x270

Scaldotto - Plaid

cm 150x180

Disponibile con imbottitura fissa o estraibile.

Available with extractable or fixed filling.

SU MISURA

Ogni modello proposto può essere personalizzato nelle dimensioni e nell'imbottitura e confezionato utilizzando i tessuti e i velluti di tutte le collezioni l'Opificio

BESPOKE

Each model can be personalized in the dimensions and in the filling and it can be manufactured making use of the wide offer of the l'Opificio Fabrics and Velvets Collections.

UTILIZZARE IL SEGUENTE FORM:

PLEASE USE THE FOLLOWING FORM:

QUANTITÀ/QUANTITY: n° _____

MISURE/DIMENSIONS: cm _____

① TOP 1 tessuto/fabric:

② BORDO/BORDER

③ PROFILO INTERNO /INTERIOR EDGE

④ PROFILO ESTERNO /EXTERIOR EDGE

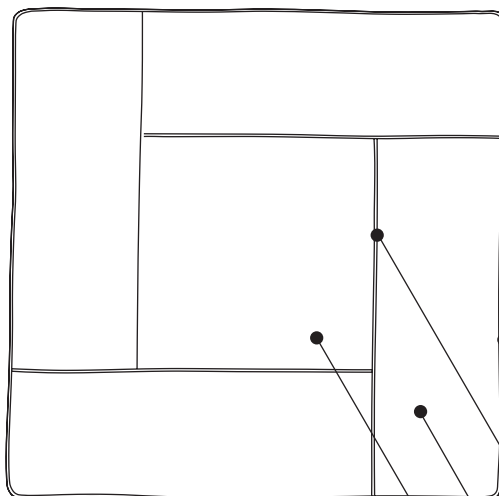

① TOP 1 tessuto/fabric

Indica il tessuto o velluto della parte centrale del trapuntino.
Indicates the fabric or velvet of the central part of the quilt.

② BORDO/BORDER

③ PROFILO INTERNO /INTERIOR EDGE

④ PROFILO ESTERNO /EXTERIOR EDGE

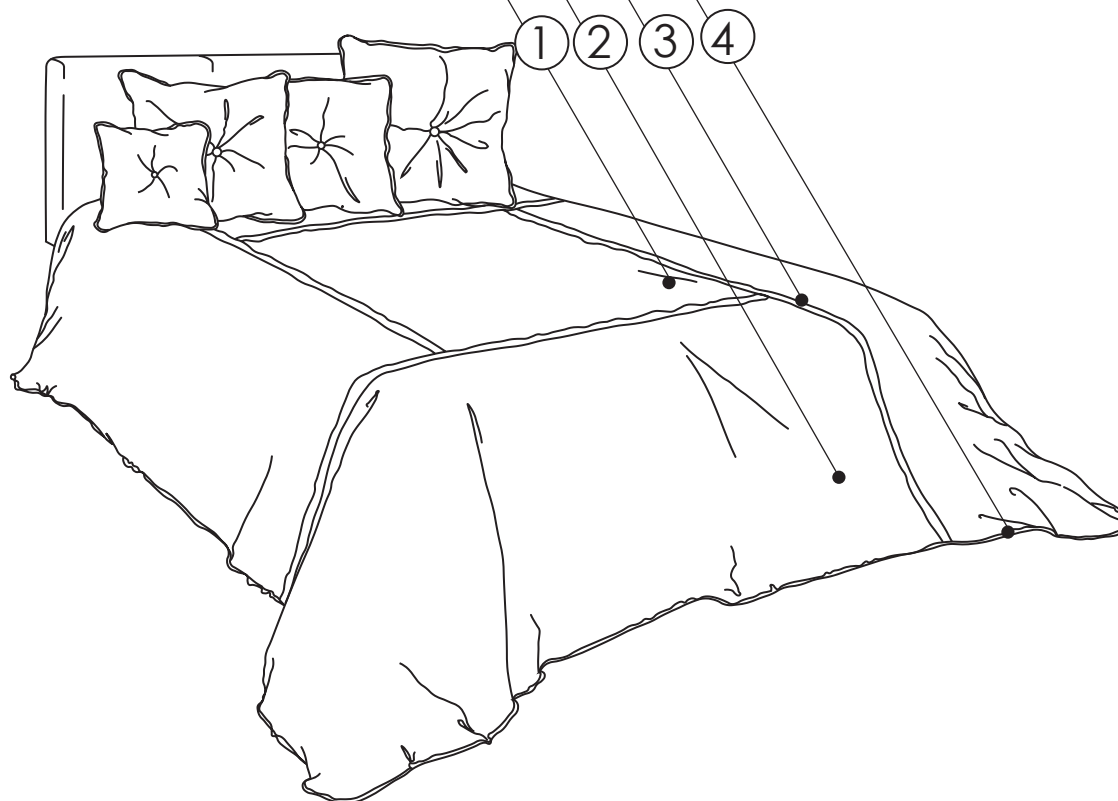

Le Collezioni

MISURE/DIMENSIONS

Matrimoniale - Double Bed

cm 240x240 / cm 270x270

Scaldotto - Plaid

cm 162x130

Disponibile con imbottitura fissa.

Available with fixed filling.

SU MISURA

Ogni modello proposto può essere personalizzato nelle dimensioni e nell'imbottitura e confezionato utilizzando i tessuti e i velluti di tutte le collezioni l'Opificio

BESPOKE

Each model can be personalized in the dimensions and in the filling and it can be manufactured making use of the wide offer of the l'Opificio Fabrics and Velvets Collections.

UTILIZZARE IL SEGUENTE FORM:
PLEASE USE THE FOLLOWING FORM:

QUANTITÀ/QUANTITY: n° _____

MISURE/DIMENSIONS: cm _____

① TOP 4 tessuti/fabrics:

② BORDO/BORDER

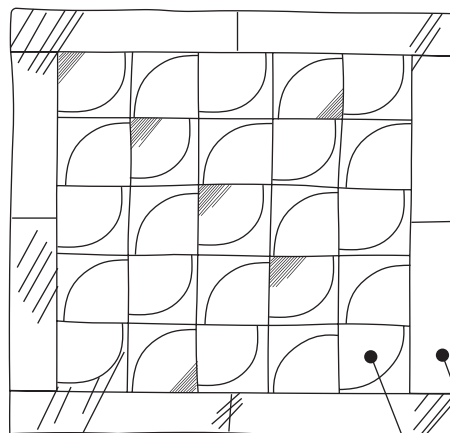

① TOP 4 tessuti/fabrics

Indica tutti i tessuti e velluti della parte centrale del trapuntino.
Indicates all the fabrics and velvet of the central part of the quilt.

② BORDO/BORDER



Optical

MISURE/DIMENSIONS

Matrimoniale - Double Bed

cm 240x240 / cm 270x270

Scaldotto - Plaid

cm 130x130

Disponibile con imbottitura fissa o estraibile.

Available with extractable or fixed filling.

SU MISURA

Ogni modello proposto può essere personalizzato nelle dimensioni e nell'imbottitura e confezionato utilizzando i tessuti e i velluti di tutte le collezioni l'Opificio

BESPOKE

Each model can be personalized in the dimensions and in the filling and it can be manufactured making use of the wide offer of the l'Opificio Fabrics and Velvets Collections.

UTILIZZARE IL SEGUENTE FORM:
PLEASE USE THE FOLLOWING FORM:

QUANTITÀ/QUANTITY: n° _____

MISURE/DIMENSIONS: cm _____

① TOP 4 tessuti/fabrics:

② PROFILO/EDGE

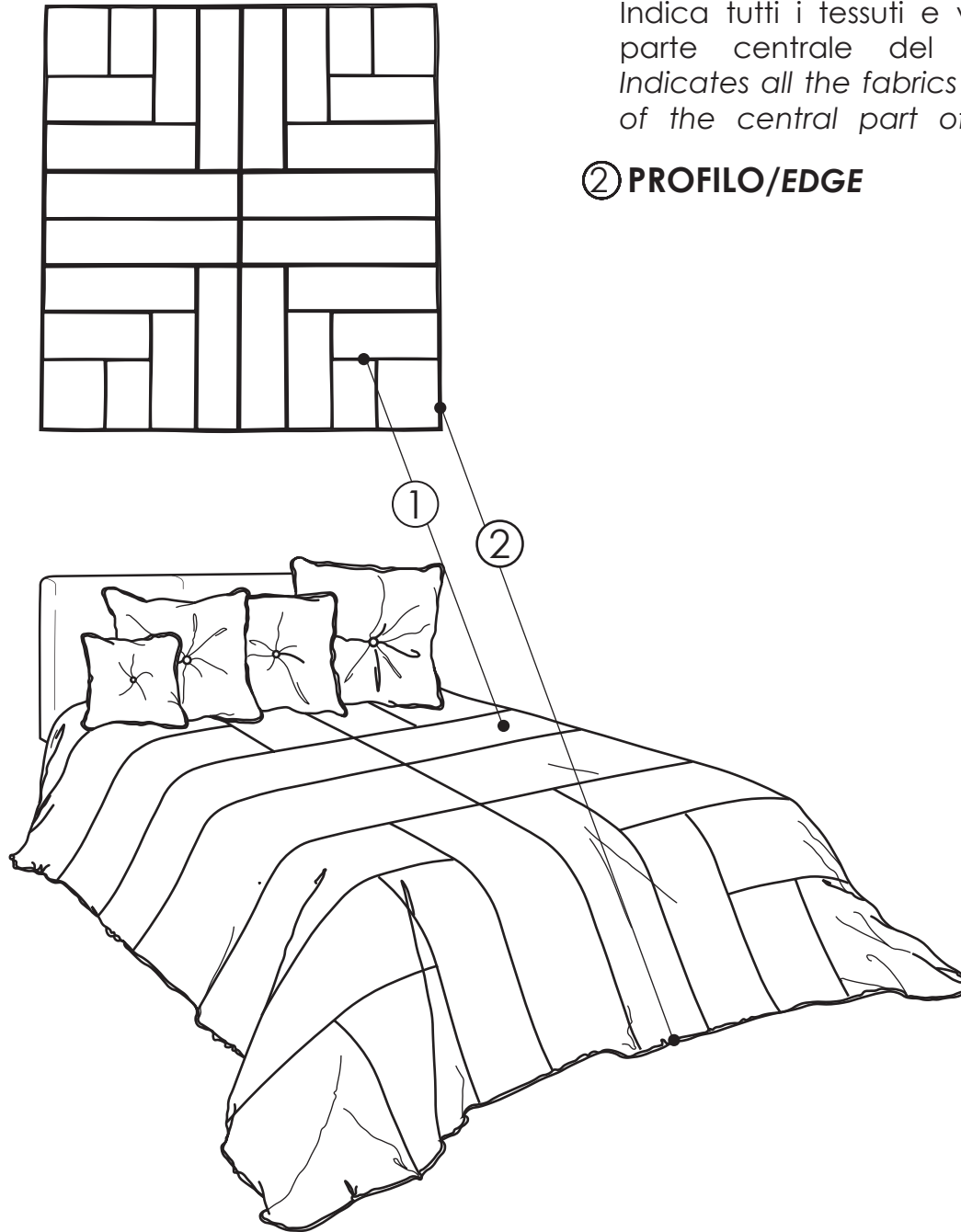

① TOP 4 tessuti/fabrics

Indica tutti i tessuti e velluti della parte centrale del trapuntino.
Indicates all the fabrics and velvet of the central part of the quilt.

② PROFILO/EDGE

Rebous

MISURE/DIMENSIONS

Matrimoniale - Double Bed

cm 240x240 / cm 270x270

Disponibile con imbottitura fissa o estraibile.

Available with extractable or fixed filling.

SU MISURA

Ogni modello proposto può essere personalizzato nelle dimensioni e nell'imbottitura e confezionato utilizzando i tessuti e i velluti di tutte le collezioni l'Opificio

BESPOKE

Each model can be personalized in the dimensions and in the filling and it can be manufactured making use of the wide offer of the l'Opificio Fabrics and Velvets Collections.

UTILIZZARE IL SEGUENTE FORM:
PLEASE USE THE FOLLOWING FORM:

QUANTITÀ/QUANTITY: n° _____

MISURE/DIMENSIONS: cm _____

① TOP 4 tessuti/fabrics:

② PROFILO/EDGE

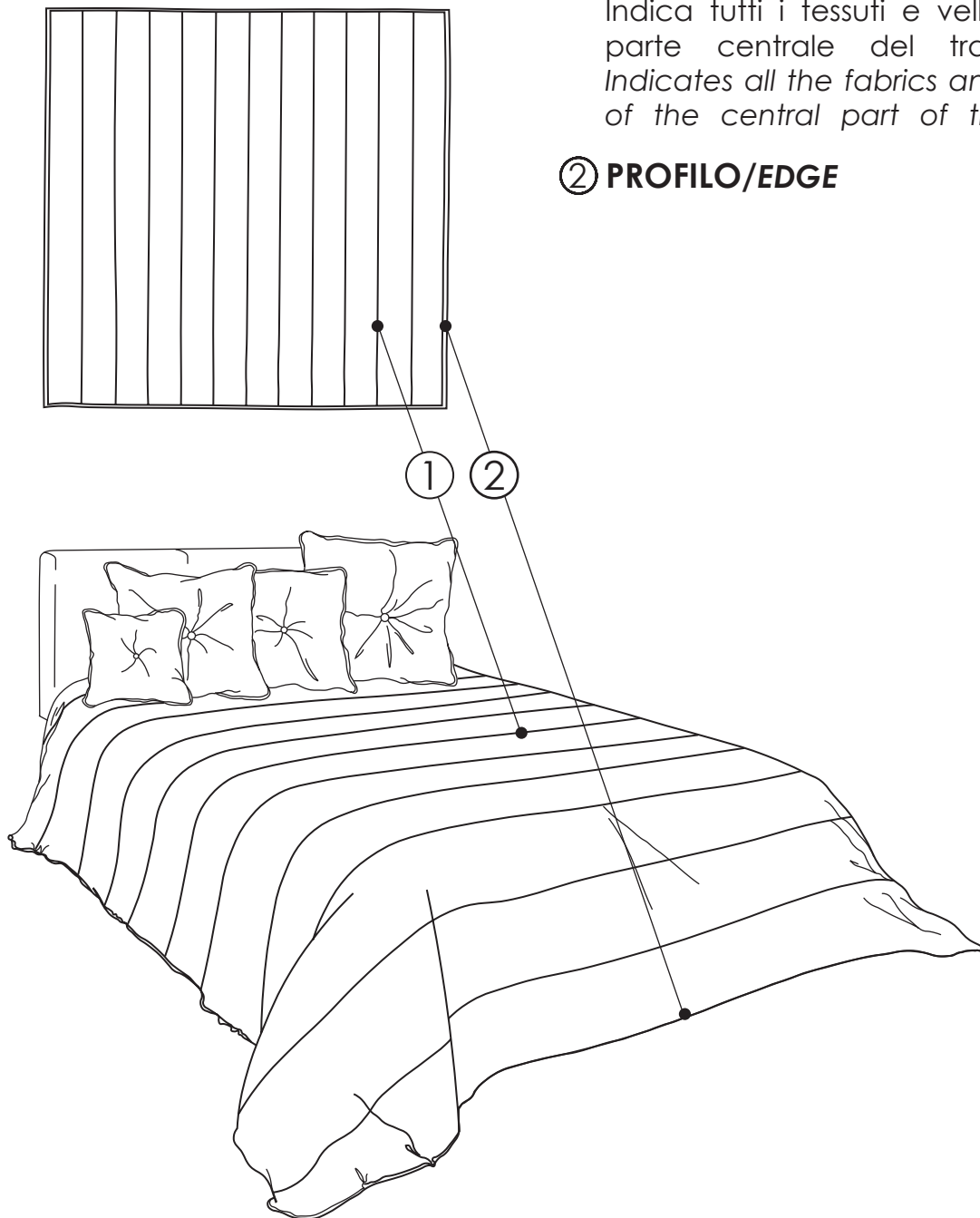

① TOP 4 tessuti/fabrics

Indica tutti i tessuti e velluti della parte centrale del trapuntino.
Indicates all the fabrics and velvet of the central part of the quilt.

② PROFILO/EDGE

Smart

MISURE/DIMENSIONS

Matrimoniale - Double Bed

cm 240x240 / cm 270x270

Scaldotto - Plaid

cm 150x180

Disponibile con imbottitura fissa o estraibile.

Available with extractable or fixed filling.

SU MISURA

Ogni modello proposto può essere personalizzato nelle dimensioni e nell'imbottitura e confezionato utilizzando i tessuti e i velluti di tutte le collezioni l'Opificio

BESPOKE

Each model can be personalized in the dimensions and in the filling and it can be manufactured making use of the wide offer of the l'Opificio Fabrics and Velvets Collections.

UTILIZZARE IL SEGUENTE FORM:

PLEASE USE THE FOLLOWING FORM:

QUANTITÀ/QUANTITY: n° _____
MISURE/DIMENSIONS: cm _____
① TOP 3 tessuti/fabrics: _____ _____ _____
② PROFILO INTERNO /INTERIOR EDGE _____
③ PROFILO ESTERNO /EXTERIOR EDGE _____

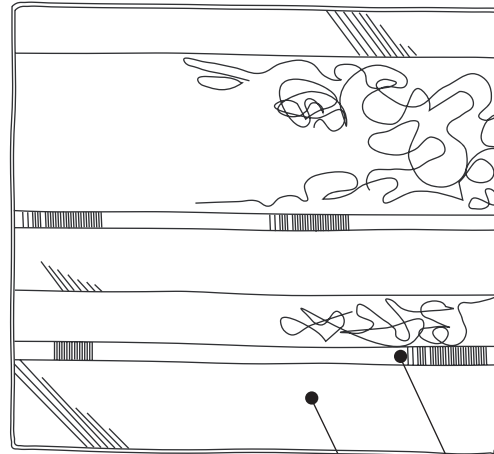

① TOP 3 tessuti/fabrics

Indica tutti i tessuti e velluti della parte centrale del trapuntino.
Indicates all the fabrics and velvet of the central part of the quilt.

② PROFILO INTERNO /INTERIOR EDGE

applicazione banda 5 cm
band 5 cm application .

③ PROFILO ESTERNO /EXTERIOR EDGE

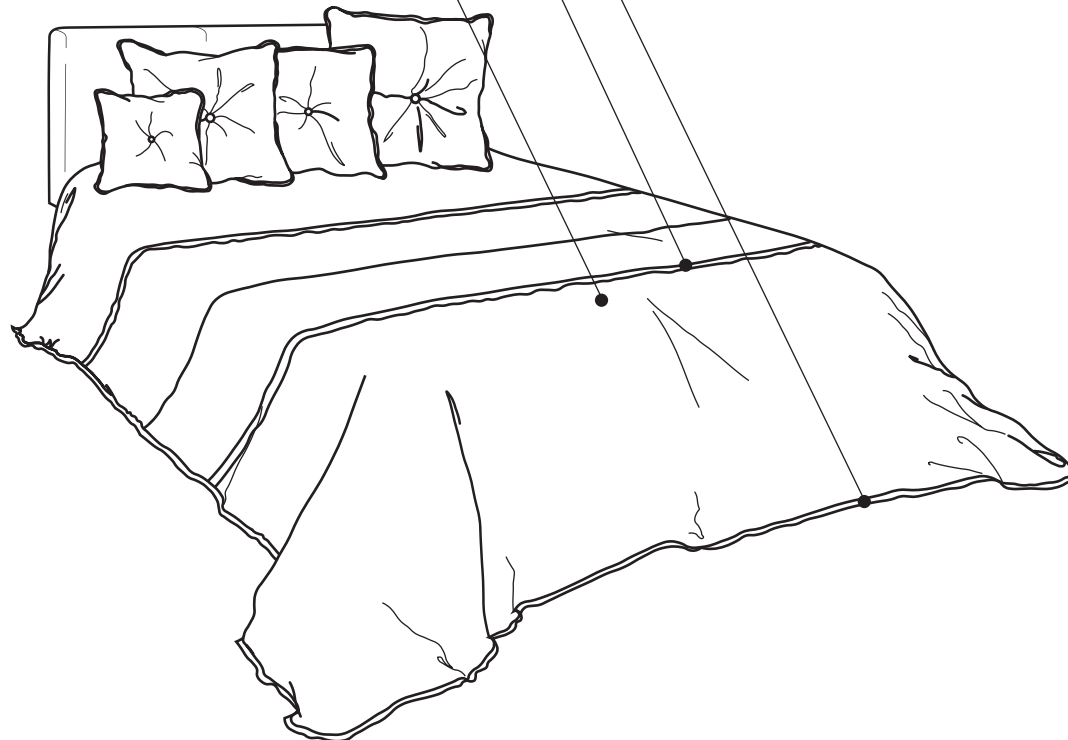

Kaleido

MISURE/DIMENSIONS

Matrimoniale - Double Bed

cm 240x240 / cm 270x270

Scaldotto - Plaid

cm 150x180

Disponibile con imbottitura fissa.
Available with fixed filling.

SU MISURA

Ogni modello proposto può essere personalizzato nelle dimensioni e nell'imbottitura e confezionato utilizzando i tessuti e i velluti di tutte le collezioni l'Opificio

BESPOKE

Each model can be personalized in the dimensions and in the filling and it can be manufactured making use of the wide offer of the l'Opificio Fabrics and Velvets Collections.

UTILIZZARE IL SEGUENTE FORM:
PLEASE USE THE FOLLOWING FORM:

QUANTITÀ/QUANTITY: n° _____
MISURE/DIMENSIONS: cm _____
① TOP 3 tessuti/fabrics:

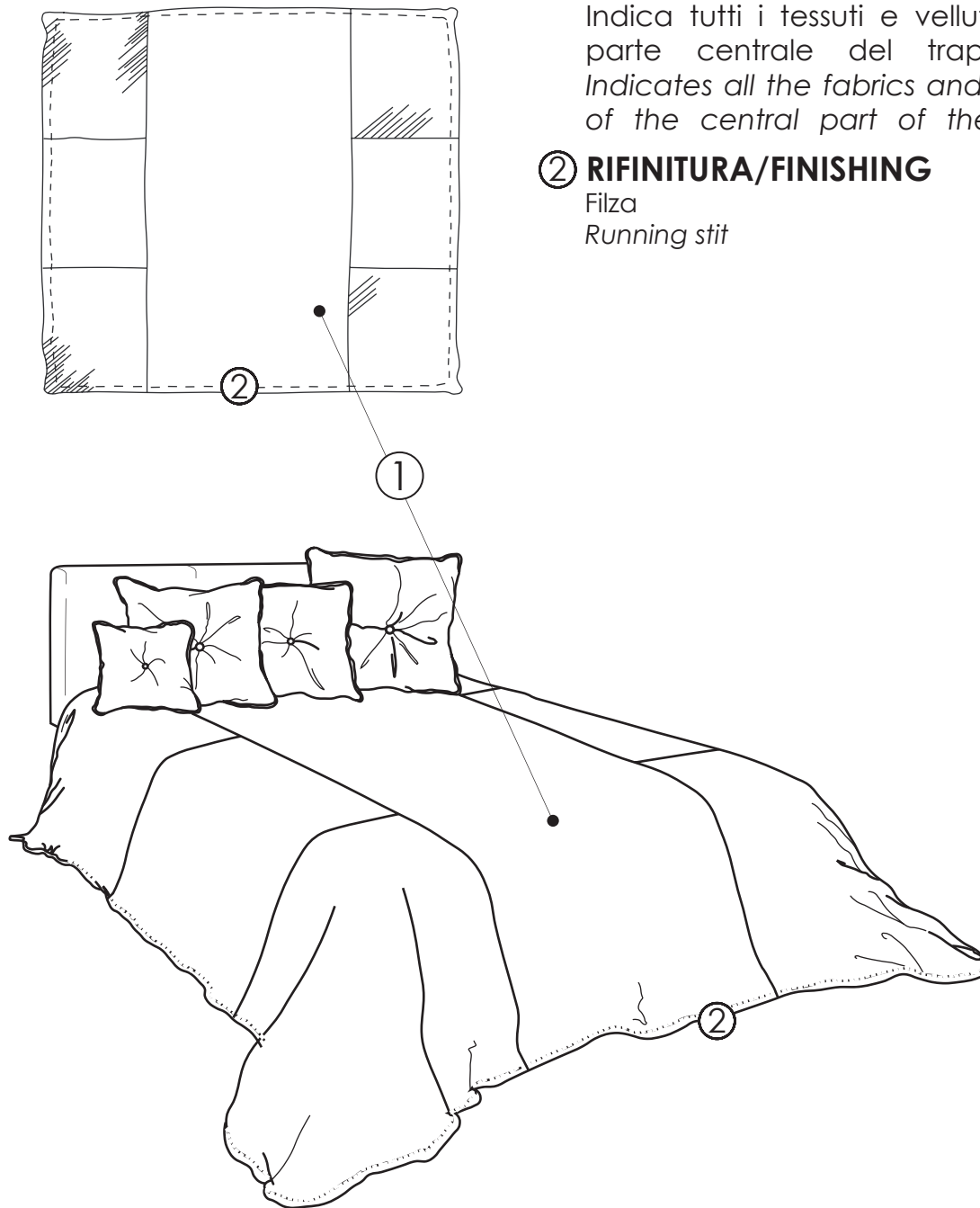

① TOP 3-4 tessuti/fabrics

Indica tutti i tessuti e velluti della parte centrale del trapuntino.
Indicates all the fabrics and velvet of the central part of the quilt.

② RIFINITURA/FINISHING

Filza
Running stit

Shiro

MISURE/DIMENSIONS

Matrimoniale - Double Bed

cm 240x240 / cm 270x270

Scaldotto - Plaid

cm 150x180

MODEL: MOSAIC

Disponibile con imbottitura fissa o estraibile.

Available with extractable or fixed filling.

SU MISURA

Ogni modello proposto può essere personalizzato nelle dimensioni e nell'imbottitura e confezionato utilizzando i tessuti e i velluti di tutte le collezioni l'Opificio

BESPOKE

Each model can be personalized in the dimensions and in the filling and it can be manufactured making use of the wide offer of the l'Opificio Fabrics and Velvets Collections.

UTILIZZARE IL SEGUENTE FORM:

PLEASE USE THE FOLLOWING FORM:

QUANTITÀ/QUANTITY: n° _____
MISURE/DIMENSIONS: cm _____
① TOP 3 tessuti/fabrics:

② PROFILO/EDGE

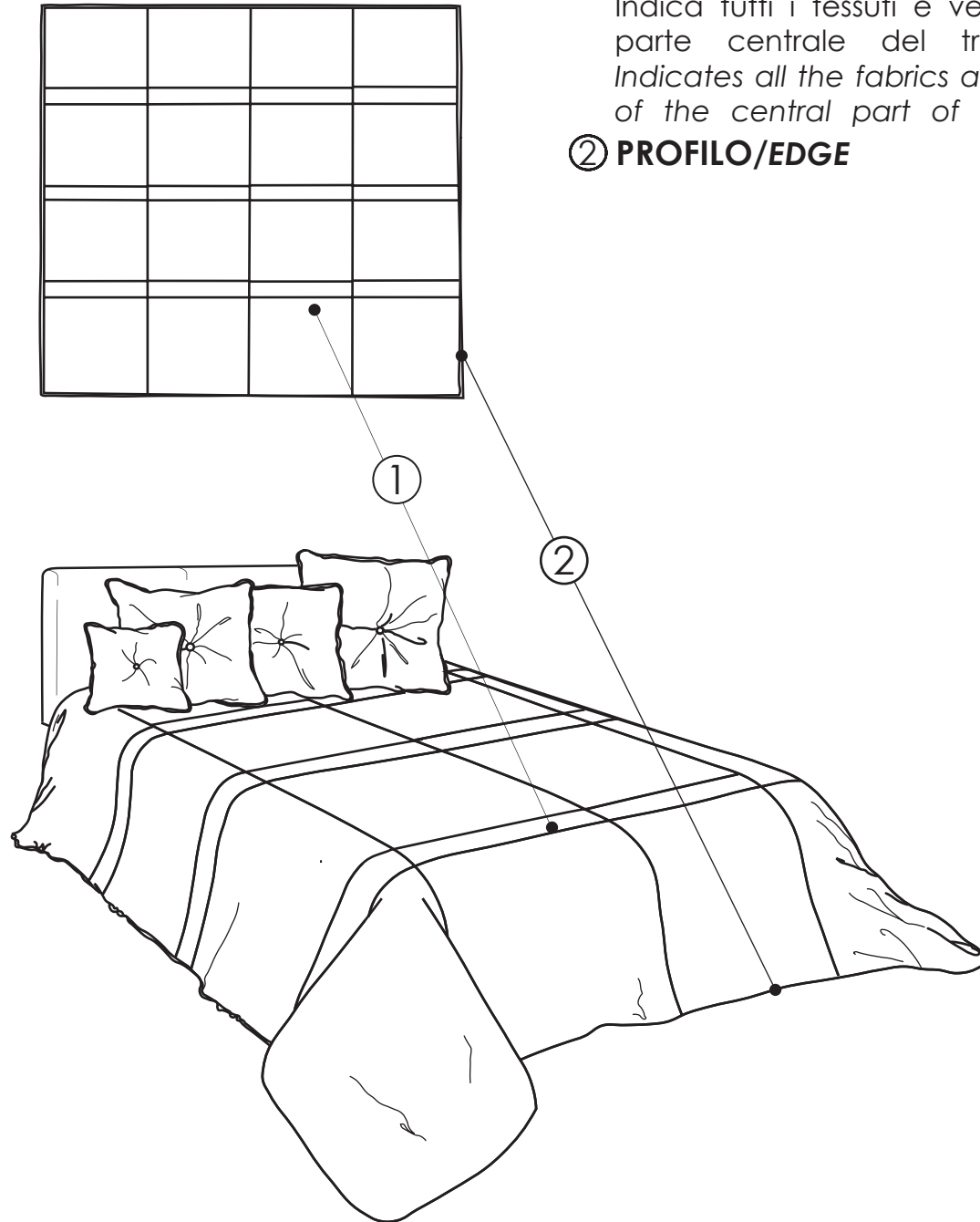

① TOP 3 tessuti/fabrics

Indica tutti i tessuti e velluti della parte centrale del trapuntino.
Indicates all the fabrics and velvet of the central part of the quilt.

② PROFILO/EDGE

Mosaic

MISURE/DIMENSIONS

Matrimoniale - Double Bed

cm 240x240 / cm 270x270

Scaldotto - Plaid

cm 150x180

Disponibile con imbottitura fissa o estraibile.

Available with extractable or fixed filling.

SU MISURA

Ogni modello proposto può essere personalizzato nelle dimensioni e nell'imbottitura e confezionato utilizzando i tessuti e i velluti di tutte le collezioni l'Opificio

BESPOKE

Each model can be personalized in the dimensions and in the filling and it can be manufactured making use of the wide offer of the l'Opificio Fabrics and Velvets Collections.

UTILIZZARE IL SEGUENTE FORM:

PLEASE USE THE FOLLOWING FORM:

QUANTITÀ/QUANTITY: n° _____

MISURE/DIMENSIONS: cm _____

① TOP 2 tessuti/fabrics:

② BORDO/BORDER

③ PROFILO/EDGE

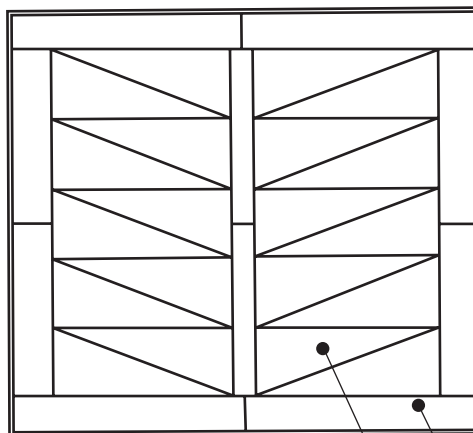

① TOP 2 tessuti/fabrics

Indica tutti i tessuti e velluti della parte centrale del trapuntino.
Indicates all the fabrics and velvet of the central part of the quilt.

② BORDO/BORDER

③ PROFILO/EDGE

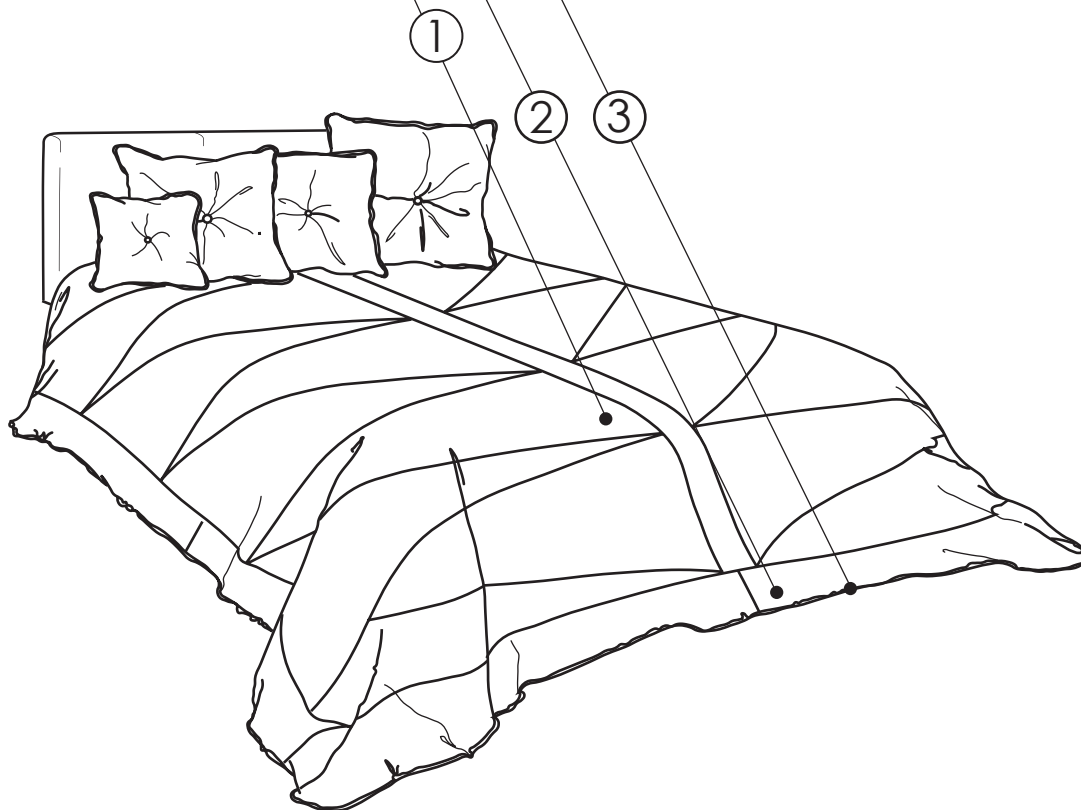

Eclettica

MODELLI
Cuscini
 MODELS CUSHIONS

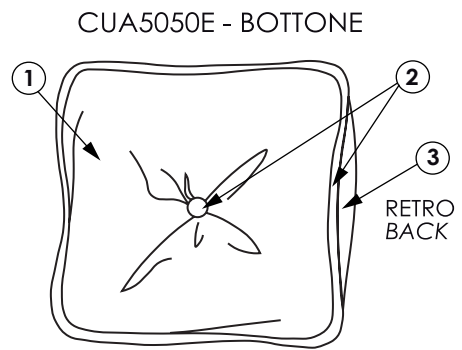
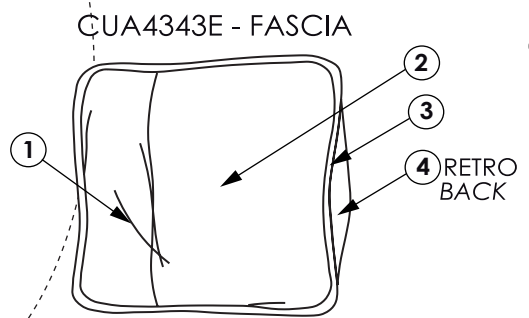
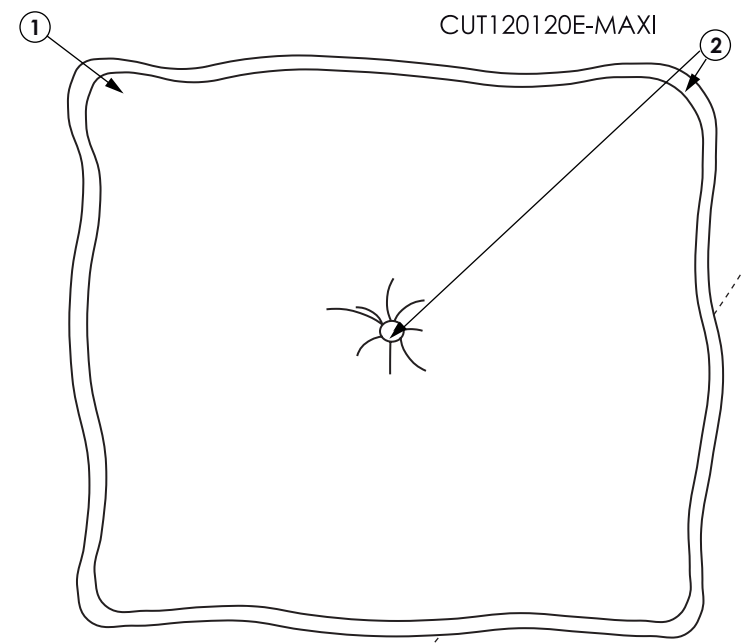
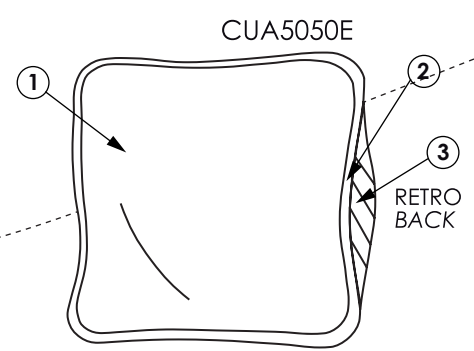
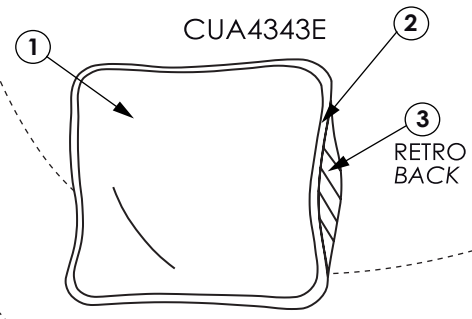
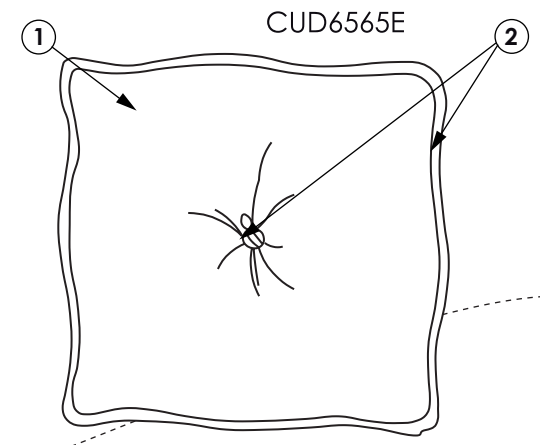
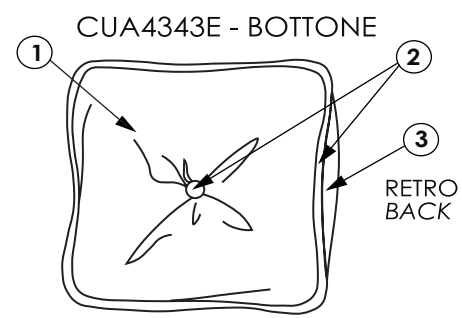
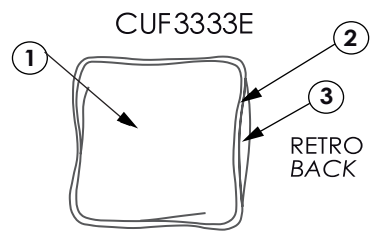

I numeri indicano la disposizione dei tessuti / The numbers indicate the fabrics positions

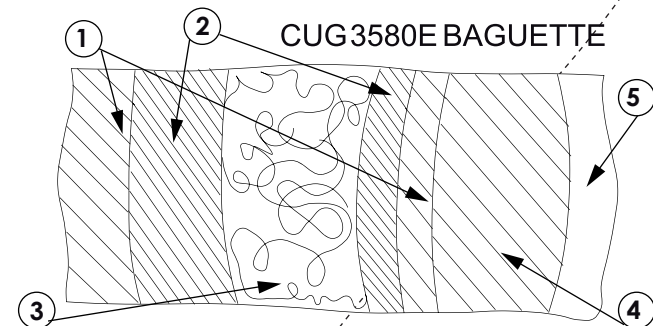
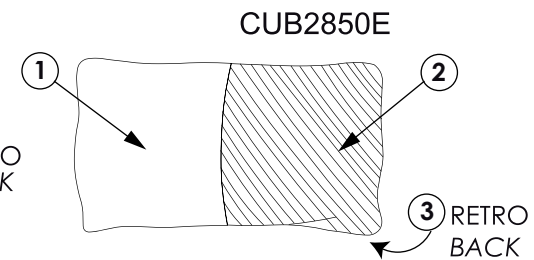
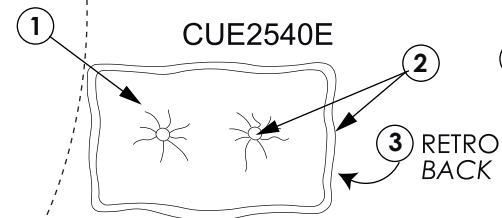
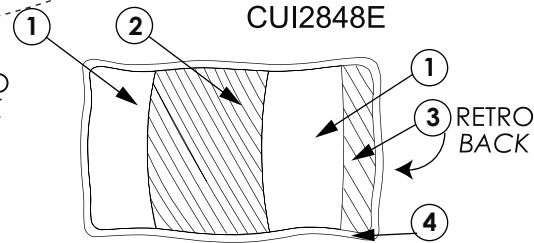
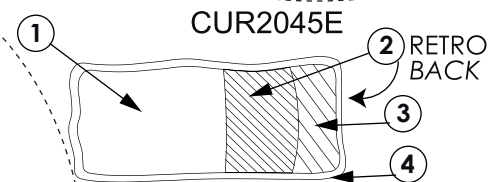
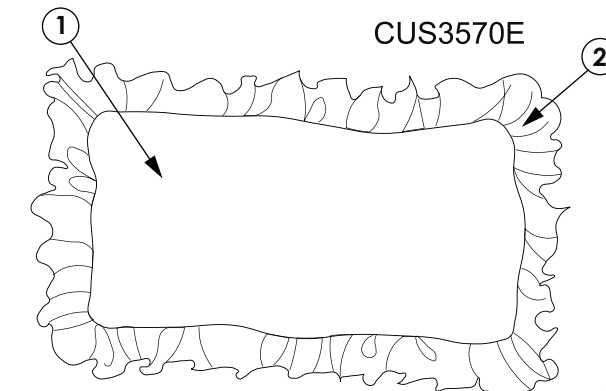
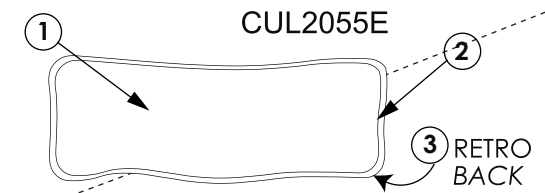
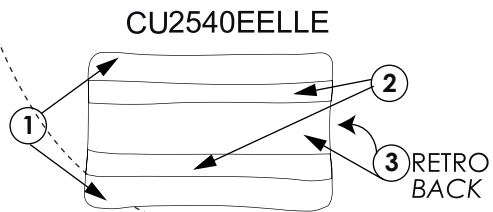
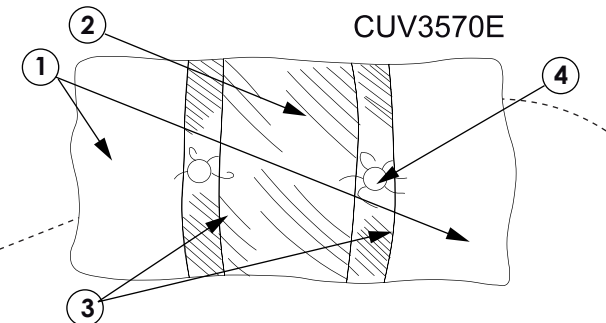
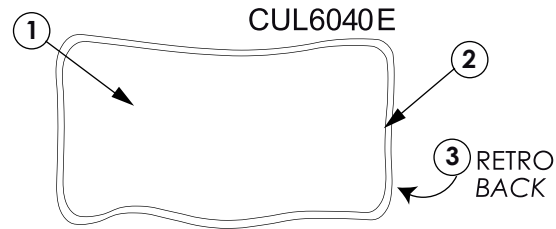
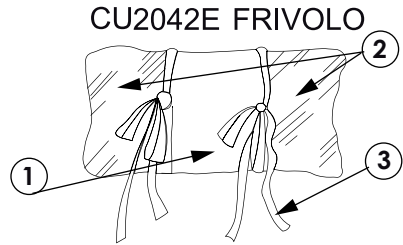
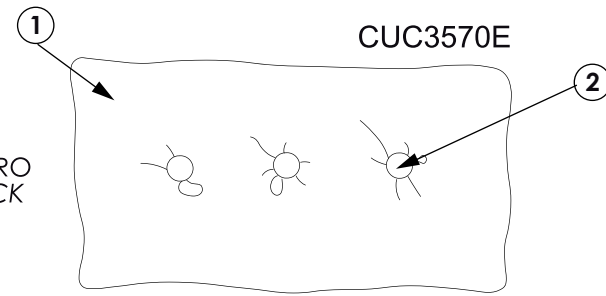
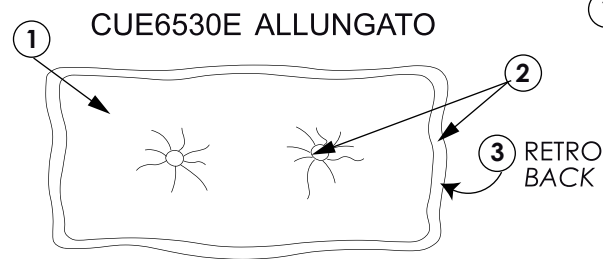
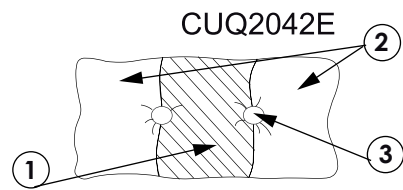

MODELLI
CUSCINI
 MODELS CUSHIONS

I numeri indicano la disposizione dei tessuti / Numbers indicate the fabrics positions

MODELLI
Cuscini
 MODELS CUSHIONS

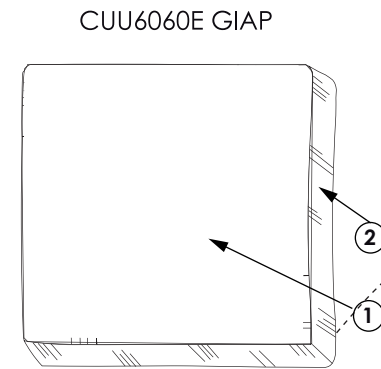
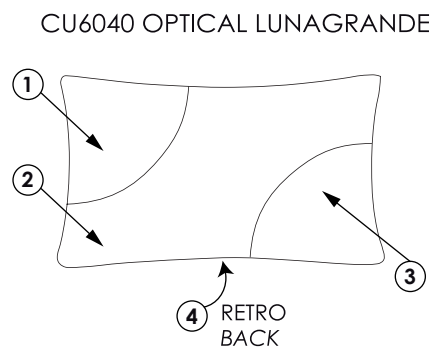
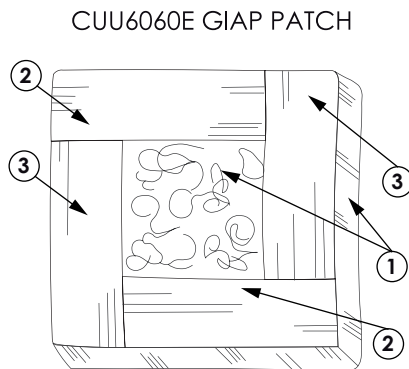
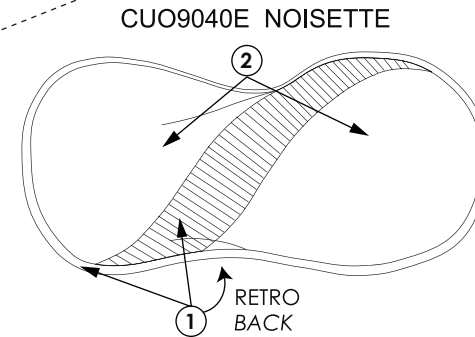
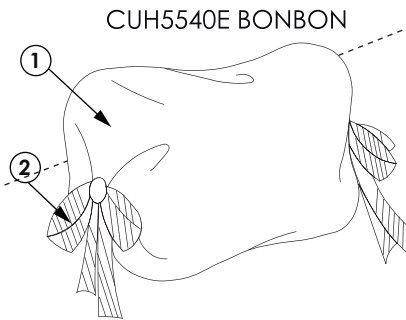
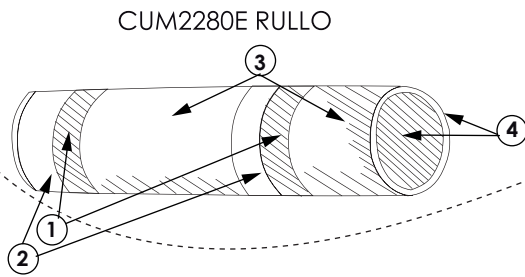
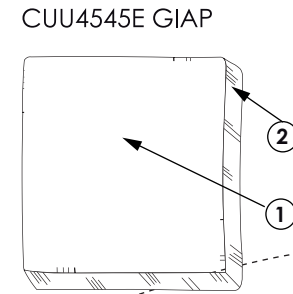
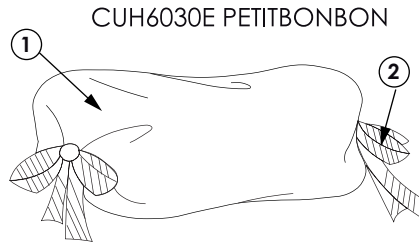
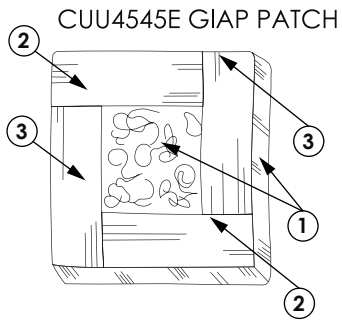

I numeri indicano la disposizione dei tessuti / Numbers indicate the fabrics positions

CURA E LAVAGGIO

Poche e semplici attenzioni da consigliare per il momento del lavaggio permettono di conservare ogni capo intatto nel tempo.

Si consiglia unicamente il lavaggio a secco che, nel caso di copriletti, trapuntini e cuscini è preferibile effettuare previa trapuntatura con filo da imbastire.

Per i capi realizzati in velluto di cotone eventuali ammaccature possono essere facilmente eliminate svaporando senza poggiare il ferro. Anche per questi capi si consiglia il lavaggio a secco per mantenere inalterato lo speciale trattamento antiacqua e antimacchia.

(fig. 02)



Trapuntare a punto molto lungo in tutta l'ampiezza del trapuntino (fig. 01). con filo da imbastire ed ago sottile (fig. 02).

(fig. 01)

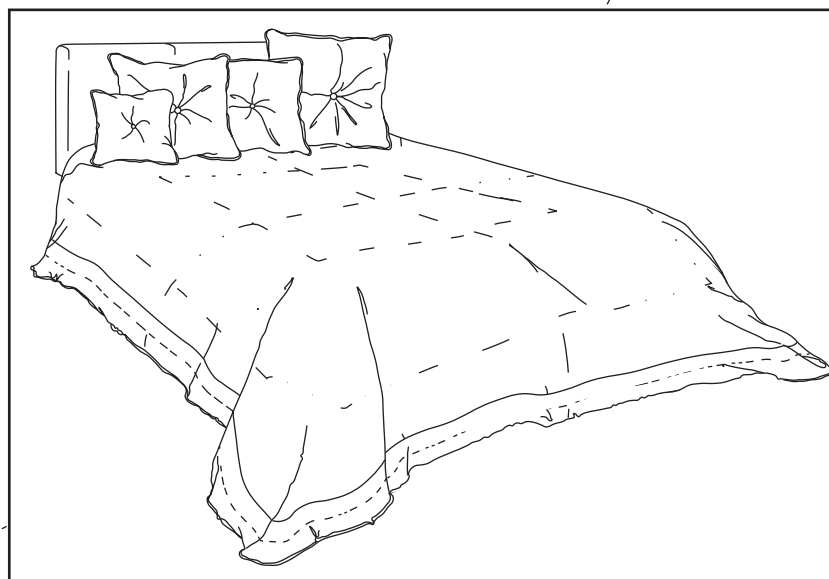

...CUSCINI

Tutti i modelli hanno imbottitura estraibile a scelta in 100% Dacron anallergico oppure in finissima piuma naturale.

...MATERASSI

Tutti i modelli hanno imbottitura 100% Dacron leggera, sostenuta e anallergica. Si può scegliere tra la classica finitura materasso "a ciuffo" oppure quella capitonné con i bottoni.

...POUF

Tutti i modelli hanno imbottitura 100% espanso ad alta densità, compatta e leggera, per una seduta confortevole. Tutti i modelli hanno la fodera estraibile per una facile manutenzione.

...IMBOTTITURE

Si propongono esclusivamente imbottiture anallergiche e di facile manutenzione: 100% Dacron (fiocco di poliestere) e 100% cotone, a scelta nella versione fissa o estraibile.

Nella versione estraibile il capo è completamente foderato internamente e vive, oltre che come trapuntino, anche come copriletto se utilizzato senza l'imbottitura interna.



CARE AND WASHING INSTRUCTIONS

A little care and a correct laundering will give you many years of enjoyment.

We recommend only dry cleaning.

Quilted articles and cushions should be basted before laundering.

For cotton velvet articles pressure marks can easily be eliminated using a steam iron without touching the fabric. For these articles too we advise dry cleaning to maintain the water and stain resistance treatment.

(fig. 02)

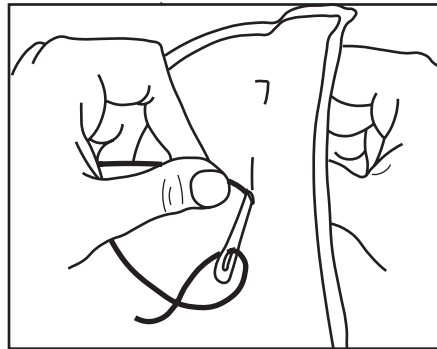

Baste with widely-spaced stitches all the width of the quilt (fig. 01) with fine thread and fine needle (fig. 02).

(fig. 01)

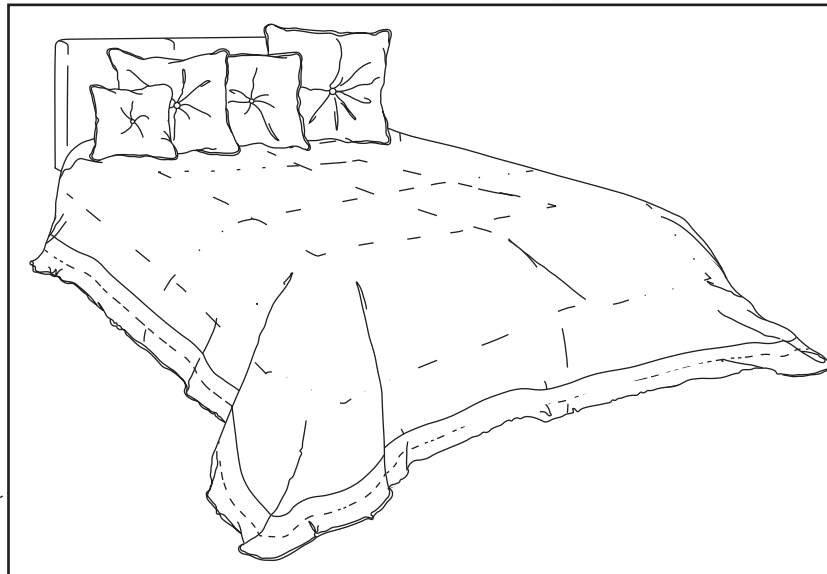

...CUSHIONS

All models have extractable anallergic 100% Dacron filling or superfine natural feather.

...MATTRESSES

All models have 100% Dacron anallergic, light firm filling.
The mattresses are proposed in the classic finishing flock or capitonnè.

...POUFS

All model have a 100% high density expanded filling, light and compact for comfortable seating.
All models have extractable filling for easy care.

...FILLINGS

L'Opificio proposes only anallergic, easy care fillings: 100% Dacron or 100% pure cotton.
The filling can be fixed or removable.
The bed throw with removable filling is completely lined internally and has a lined filling too. If used without filling it is a perfect bedspread as well.

